

CODE ALARM

PROFESSIONAL SERIES

Remote Start with Keyless Entry Installation Guide

CA 5550SST

Table of Contents

Before You Begin	3
Wire Connection Guide	4
7 Pin Main Harness	5
3 Pin Parking Light Harness	7
6 Pin Start Harness	8
4 Pin Alternate Harness	9
2 Pin Door Lock Harness	10
Additional Ports	14
Antenna / LED / Programming Port	14
DBI Port	14
Tracking Port	14
Set Up & Programming	15
Transmitter Programming	15
Manual Feature Programming	15
Programming Feature Banks	16
Tach Programming	17
Smart Tachless Mode	17
Feature Descriptions	18
Transmitter Button Functions	21
Remote Start Shutdown Diagnostics	22
System Layout	23

BEFORE YOU BEGIN

PROFESSIONAL INSTALLATION STRONGLY RECOMMENDED

Installation Precautions:



Roll down window to avoid locking keys in vehicle during installation



Avoid mounting components or routing wires near hot surfaces



Avoid mounting components or routing wires near moving parts



Tape or loom wires under hood for protection and appearance



Use grommets when routing wires through metal surfaces



Use a Digital Multi Meter for testing and verifying circuits. **DO NOT USE A TEST LIGHT, OR "COMPUTER SAFE PROBE"** as these can set off air bags or damage vehicle computers.



Technical Support (800) 421-3209
or go to
<http://techservices.codesystems.com>

7 Pin Main Harness

7 PIN MAIN	1	BLACK/WHITE	ILLUMINATED ENTRY OUTPUT (-)
	2	BROWN/BLACK	HORN OUTPUT (-)
	3	RED/WHITE	TRUNK RELEASE OUTPUT (-)
	4	BLUE/BLACK	IGNITION 3 (-)
	5	PURPLE/WHITE	TACH INPUT
	6	GRAY	HOOD PIN INPUT (-)
	7	BROWN/RED	BRAKE INPUT (+)

3 Pin Parking Light Harness

3 PIN LIGHTS	1	BLACK	GROUND
	2	WHITE/RED	PARKING LIGHT INPUT
	3	WHITE	PARKING LIGHT OUTPUT

6 Pin Start Harness

6 PIN START	1	PURPLE	STARTER OUTPUT - MOTOR SIDE
	2	RED	BATTERY 12V (+)
	3	ORANGE	ACCESSORY 1 (+)
	4	PINK/WHITE	IGNITION 2 (+)
	5	RED	BATTERY 12V (+)
	6	PINK	IGNITION 1 (+)

4 Pin Alternate Harness

4 PIN ALTERNATE OUTPUT	1	LT GREEN/BLACK	FACTORY DISARM / PULSE BEFORE START (-)
	2	LT BLUE	PULSE AFTER START (-)
	3	GREEN/WHITE	FACTORY ARM / PULSE AFTER SHUTDOWN (-)
	4	BLACK/YELLOW	PULSE DURING CRANK (-)

2 Pin Lock Harness

2 PIN LOCK	1	BLUE	UNLOCK (-)
	2	GREEN	LOCK (-)

7 Pin Main Harness

1	BLACK/WHITE	ILLUMINATED ENTRY OUTPUT (-)
---	-------------	------------------------------

This wire provides a (-) 500mA output for 30 seconds when the system is disarmed capable of driving relays.

Locate the vehicle's dome light or pin switch wire.

Verification: This wire will register positive voltage or ground when the vehicle's dome light is turned ON.

2	BROWN/BLACK	HORN OUTPUT (-)
---	-------------	-----------------

Locate the vehicle's horn wire.

Verification: This wire will register at positive voltage and register ground when the horn switch is pressed.

Connect the BROWN/BLACK wire to the vehicle's horn wire. This is a low current output, 500mA.

3	RED/WHITE	TRUNK RELEASE OUTPUT (-)
---	-----------	--------------------------

Locate the vehicle's trunk release wire at the trunk release switch.

Verification: This wire will register either positive voltage or ground when the trunk release is activated.

This is a low current output, 500mA.

4	BLUE/BLACK	IGNITION 3 / ACTIVE OUTPUT (-)
---	------------	--------------------------------

The Active Output/Ignition 3 output wire provides a ground output when the remote start function is activated and remains until 4 seconds after the remote start is shutdown. The Ignition 3 output wire can be used for several functions listed below. If this wire will be used for multiple application's a 1 amp diode is required in-line with the stripe facing the control module.

Factory transponder (coded key) bypass.

General Motors VATS bypass, see the following diagram. Use an SPDT relay (not supplied).

Ignition 3 output, see the following diagram. Use an SPDT relay (not supplied).

Accessory 2/3 output, see the following diagram. Use an SPDT relay (not supplied).

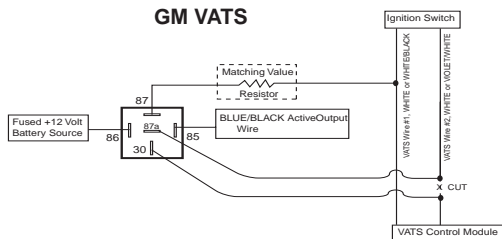

Ignition 3

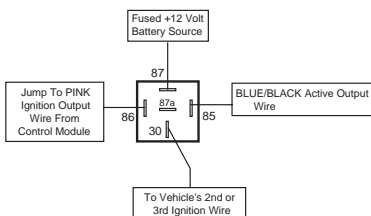

Accessory 2/3

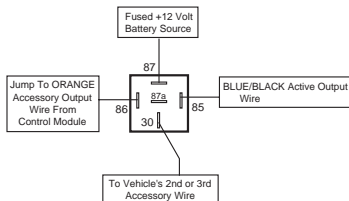

5 PURPLE/WHITE

TACH INPUT

Locate the vehicle's ignition coil or fuel injector in the engine compartment.

Verification: Test using the following procedure:

1. Set voltmeter to AC VOLTS.
2. Attach positive lead of a volt meter to a constant 12-volt source.
3. Attach negative lead of a volt meter to the wire to be tested.
4. Start the engine.
5. Have someone press on the gas pedal slightly as you monitor the meter. If connected to the correct wire, the voltage reading will increase as the engine's RPM increases.

Connect the PURPLE/WHITE wire to the negative side of the vehicle ignition coil or fuel injector.

6 GRAY

HOOD PIN INPUT (-)

Install a Hood Pin Switch and connect to the GRAY wire. This connection is required for Remote Start.

Verification: This wire when connected will register ground when the vehicle's hood is opened.

Connect the GRAY wire to the hood pin.

NOTE: Be sure to loom the wire, and seal the grommet.

7 BROWN/RED

BRAKE INPUT (+)

Locate the vehicle's brake light wire at the brake pedal mounted switch.

Verification: This wire registers positive voltage when the brake pedal is pressed.

Connect the BROWN/RED wire to the vehicle's brake light wire.

3 Pin Parking Light Harness

1 BLACK

GROUND

Connect the BLACK wire to a solid chassis ground point using a ring terminal and self tapping screw (not supplied). Scrape away paint from the grounding point to ensure a good connection. The recommended grounding point is a metal surface in the driver's side kick panel area.

NOTE: Do not ground the BLACK wire with any other vehicle components.

2 WHITE/RED

PARKING LIGHT INPUT

3 WHITE

PARKING LIGHT OUTPUT

Locate the parking light output wire at the vehicle's light switch.

Verification: This wire registers positive voltage when the parking lights are turned on.

Positive switching Parking Lights:

Connect the WHITE/RED wire to a 15 Amp max fused battery source.

Connect the WHITE wire to the parking light output wire.

Negative switching Parking Lights:

Connect the WHITE/RED wire to a good chassis ground.

Connect the WHITE wire to the parking light output wire.

6 Pin Start Harness

1	PURPLE	STARTER OUTPUT (+)
---	--------	----------------------

Locate the vehicle starter wire.

Verification: This wire registers voltage *only* when the key is turned to the START position.

Verification:

The starter wire registers voltage when the key is turned to the START position.

Connect the PURPLE wire to the vehicle starter wire.

2	RED	BATTERY 12V (+)
---	-----	-------------------

Locate 1 of the vehicle's constant 12 Volt battery wires at the ignition switch.

Verification: This wire will register (+) voltage in all positions of the ignition switch.

Connect the RED wire to the constant 12 Volt battery wire.

NOTE: Remove all fuses until all connections are made.

3	ORANGE	ACCESSORY 1 (+)
---	--------	-------------------

Locate the vehicle's accessory wire at the ignition switch.

Verification: This wire registers voltage when the key is turned to ACC (Accessory) and the ON (or RUN) position. The voltage drops out when the key is turned to the START (or CRANK) position.

Connect the ORANGE wire to the vehicle's accessory wire.

4	PINK/WHITE	IGNITION 2 (+)
---	------------	------------------

Locate the vehicle's 2nd ignition wire at the ignition switch (if equipped).

Verification: This wire registers voltage when the key is turned to the ON (or RUN) position, but not the ACC (Accessory) position. The voltage does not drop out when the key is turned to the START (or CRANK) position.

Connect the PINK/WHITE wire to the vehicle's ignition 2 wire.

Programmable output: IGN, ACC, Start.

5 RED

BATTERY 12V (+)

Locate 1 of the vehicle's constant 12 Volt battery wires at the ignition switch.

Verification: This wire will register (+) voltage in all positions of the ignition switch.

Connect the RED wire to the constant 12 Volt battery wire.

NOTE: Remove all fuses until all connections are made.

6 PINK

IGNITION 1 (+)

Locate the vehicle's ignition wire at the ignition switch.

Verification: This wire registers voltage when the key is turned to the ON (or RUN) position. The voltage does not drop out when the key is turned to the START (or CRANK) position.

Connect the PINK wire to the vehicle's Ignition wire.

This wire is also used for Ignition 1 Output.

4 Pin Alternate Harness

1 LT GREEN/BLACK

FACTORY DISARM /
PULSE BEFORE START (-)

This wire will supply a (-) 500mA pulse both upon disarming the system and when the remote start feature is activated. Locate the factory perimeter alarm disarm wire from the key cylinder inside the drivers door.

Verification: This wire registers ground if the key is turned to the unlock position in the driver's door cylinder.

Connect the LIGHT GREEN/BLACK wire to the factory alarm disarm wire.

2 LT BLUE

PULSE AFTER START (-)

This wire will supply a (-) 500mA pulse both upon arming the system and upon successful completion of the remote start activation sequence and is typically used to re-lock the vehicle's doors upon remote start if necessary.

3 GREEN/WHITE

FACTORY ARM /
PULSE AFTER SHUTDOWN (-)

This wire will supply a (-) 500mA pulse after the remote start shuts down. This is typically used to re-lock the vehicle's doors if they unlock upon remote start shutdown. It can also be used to pulse a door pin-switch wire to prevent the vehicle's accessories from remaining on after remote start shutdown.

4 BLACK/YELLOW

PULSE DURING CRANK (-)

Locate the vehicle's second starter (crank) wire at the ignition switch. (if equipped)

Verification: This wire registers voltage only in the start (crank) position of the ignition switch.

Connect the BLACK/YELLOW wire as shown in the diagram below. Use an SPDT relay (not supplied).

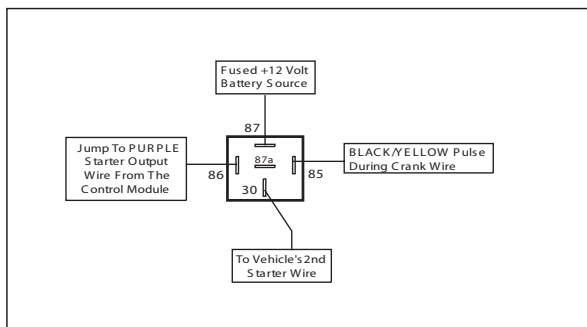

2 Pin Lock Harness

1 BLUE

UNLOCK (-)

2 GREEN

LOCK (-)

The door lock / unlock outputs are designed to control several different types of systems which may require additional parts. Please review the wire and location chart to see which type of door lock system is in your vehicle. The most common types are shown in the following diagrams.

Negative Switching Locks

All Door Lock and Unlock: Locate the lock / unlock wire at the vehicle's lock / unlock switch.

Verification: These wires will register ground when the Lock and Unlock switches are activated.

Connect the GREEN and BLUE wires shown in the diagram below.

Negative Locks:

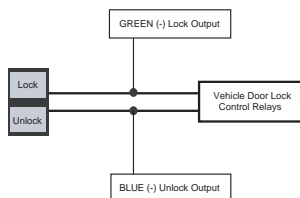

Positive Switching Locks

All Door Lock and Unlock: Locate the lock / unlock wire at the vehicle's lock / unlock switch.

Verification: These wires will register positive voltage when the Lock and Unlock switches are activated.

Connect the GREEN and BLUE wires shown in the diagram below.

Positive Locks:

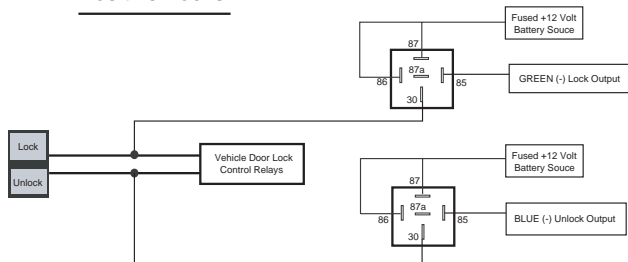

Reverse Polarity Locks (5-Wire Door locks)

All Door Lock and Unlock: Locate the lock / unlock wire at the vehicle's lock / unlock switch.

Verification: These wires will rest at ground and register positive voltage when the Lock and Unlock switches are activated.

Connect the GREEN and BLUE or BLUE/GREEN wires shown in the diagram below using (2) SPDT relays (not supplied).

Reverse Polarity Locks:

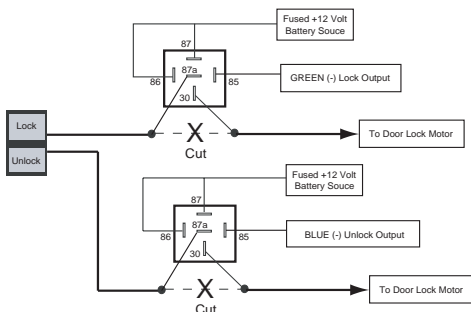

Negative Multiplexed Locks

All Door Lock and Unlock: Locate the lock / unlock wire at the vehicle's lock / unlock switch.

Verification: This wire will show variable ground when the switch is activated. Please consult the wire and location chart for specific resistor values for your vehicle.

Connect the GREEN and BLUE or BLUE/GREEN wires shown in the diagram below using (2) SPDT relays (not supplied).

Multiplex Locks:

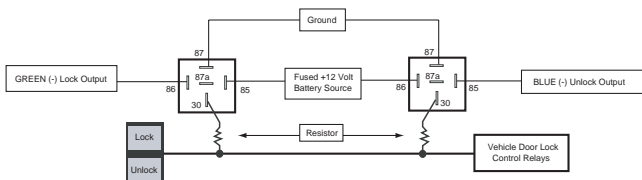

Positive Multiplexed Locks

All Door Lock and Unlock: Locate the lock / unlock wire at the vehicle's lock / unlock switch.

Verification: This wire will show variable positive voltage when the switch is activated. Please consult the wire and location chart for specific resistor values for your vehicle.

Connect the GREEN and BLUE or BLUE/GREEN wires shown in the diagram below using (2) SPDT relays (not supplied).

Multiplex Locks:

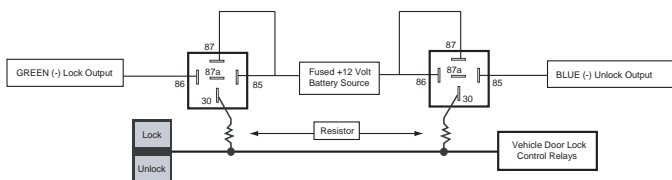

Adding Aftermarket Actuators

After installing aftermarket actuators, (not supplied). Connect the GREEN and BLUE wires shown in the diagram below using (2) SPDT relays (not supplied).

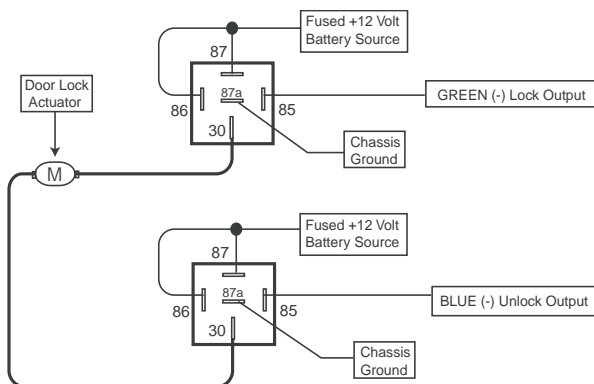

Additional Ports

Antenna / LED / Programming Port

Mount the supplied antenna/receiver to a clear spot on the vehicle's windshield that will not block the driver's vision. A good location is usually high on the windshield near the rear view mirror. Be careful not to mount the antenna/receiver on any metallic window film, as this will effect system range. Route the antenna/receiver cable to the control module and plug into the antenna port.

Data Bus Interface Port

This 4 pin port is used for Flashlogic Door Lock and Transponder Databus Interfaces to communicate with the vehicle's Databus. When using the DBI port to control the Flashlogic Door Lock and Transponder Interface modules the following options may be available. Please refer to the D2D (Data to Data) function list available per vehicle on the tech service web site.

Tach Input	Brake Safety Shut Down
Trunk/Hatch Open	Diesel Glow Plug Input
Door Lock Control	Passlock / Passkey Interface (GM Only)
Dome Light Supervision	Transponder Interface Activation
Factory Alarm Arm / Disarm	Manual Arm / Disarm Inputs (factory keyless controls system)

Tracking Port

This 4 pin port is used for Code Alarm Car Link or Vehicle Tracking accessories.

Set Up & Programming

Transmitter Programming - Feature Bank 1

1. Turn the ignition ON.
2. Press and hold the valet/override button.
3. Within 10 seconds the system will chirp (3) three times.
4. Press 1 button of each transmitter you wish to program.
5. The system will respond with 1 chirp for each accepted transmitter.
6. Pressing the override button at anytime during programming will advance to the next bank.



NOTE: The system will exit transmitter programming after 15 seconds of inactivity.

NOTE: This system has 1 button programming which programs all channels of the system.

NOTE: The system will hold up to 4 transmitters in memory, programming a 5th transmitter will erase the oldest transmitter in memory.

NOTE: This system has PTN - Programmed Transmitter Notification. Each time the ignition is turned ON, the LED will flash the number of transmitters programmed to the system.

Manual Feature Programming - Feature Bank 2 - 4

1. Turn the ignition ON.
2. Press and hold the valet/override button.
3. Within 10 seconds the system will chirp (3) three times.
4. Use the valet/override button to advance through each option bank. For feature programming advance to Feature Bank 2, 3 or 4, which is (4) four, (5) five, and (6) six chirps.
5. Use the transmitter  button to scroll through the selections in each feature bank, the system will chirp to match the feature number.
6. Press the transmitter  button to change the desired feature. The LED will flash indicating the changed feature.

Defaulting All Features: Pressing the  button anytime while in any of the feature banks will default all features and return you to feature bank 2 - 4 chirps.

NOTE: The system will remain in feature programming mode as long as the ignition is on, there is no time limit. To exit programming turn the IGNITION OFF.

**Feature Bank 1 - 3 Chirps
Transmitter Programming**

Refer to transmitter programming.

	Feature Bank 2 - 4 Chirps Security Control	1 LED Flash	2 LED flash	3 LED Flash	4 LED Flash	5 LED Flash	6 LED Flash
1	Silent Choice	ON	OFF				

	Feature Bank 3 - 5 Chirps Output Control	1 LED Flash	2 LED flash	3 LED Flash	4 LED Flash	5 LED Flash	6 LED Flash
1	Extended Lock Pulse	1 Second	3,5 Seconds	1 Second Lock, Double Pulse Unlock	30 Second Lock, Double Pulse Unlock	Double Pulse Lock, 1 Second Unlock	
2	Factory Disarm	Factory Disarm	2nd Unlock	Start Status			
3	Ignition Controlled Locks	OFF	Lock and Unlock	Lock Only	Unlock Only		
4	Horn Output Timing	16mS	10mS	30mS	40mS	50mS	
5	Real Panic	ON	OFF				

	Feature Bank 4 - 6 Chirps Remote Start Control	1 LED Flash	2 LED flash	3 LED Flash	4 LED Flash	5 LED Flash	6 LED Flash
1	RF Start Chirp	ON	OFF				
2	Run Time	15 Minutes	5 Minutes	10 Minutes	20 Minutes	45 Minutes	60 Minutes
3	Running Lights	Steady	Flashing				
4	Tach Mode	Tach	Tachless (Crank Average / Voltage)	Hybrid (Crank Average / NO Voltage)	DBI Port		
5	Voltage Level	High	Low				
6	Crank Time	1.0 Seconds	0.8 Seconds	1.5 Seconds	2.0 Seconds	4.0 Seconds	
7	Crank Averaging / Crank Time	Averaging	Preset Time				
8	Gas / Diesel	Gas	10 Second Delay	15 Second Delay	20 Second Delay	45 Second Delay	
9	Single / Double Pulse Start	Double Press	Single Press				
10	IGN 2 Output	Ignition 2	Accessory	Start / Crank			
11	2 or 3 Hour Start	3 Hour	2 Hour				

Tach Programming

The unit will not operate unless a tach signal is programmed or the tachless option is turned ON. If an attempt is made to start the vehicle via the remote start without first programming tach, the unit will flash the parking lights 7 times indicating tach has not been learned and stored. If the tach rate is not properly programmed to the specific vehicle, the unit may not realize that the vehicle is running in certain instances and reengage the starter motor.

The Remote Start unit will learn the tach rate of most vehicle's single coil, multiple coil packs, or single injector. To learn tach:

1. Turn the ignition key to the ON position.
2. Press and release the valet/override button 3 times.
3. Immediately turn the ignition key OFF.
4. Press and hold the valet/override button, then start the vehicle using the key.
5. When the unit senses the tach signal, the parking lights will begin to flash.
6. Allow the vehicle to settle to a normal idle speed.
7. Release the valet/program push-button switch. The parking lights will turn on for 2 seconds indicating that the learned tach signal is stored and the unit has exited tach learn mode.

NOTE: If the unit fails to learn tach rate due to an improper tach connection or a poor tach source, the parking lights will not flash. To correct this situation, locate and connect the PURPLE/WHITE wire to the proper tach signal, and then repeat the tach learn routine.

Smart Tachless Mode

Smart Tachless Mode is available only if a tach signal has never been learned to the system and when activated will automatically change the Tach Mode feature in option programming to Tachless without the need to enter the feature programming mode.

1. Activate the remote start. The parking lights should begin flashing 7 times indicating no tach signal has been learned.
2. Within the 7 flash time period, press and hold the  button.
3. The system will chirp 1 time indicating the system is now in tachless mode.

Feature Descriptions

Feature Bank 2 - Security

1 - Silent Choice: Controls the normal arm/disarm chirps of the security system.

ON - Silent arming/disarming upon first press of lock/unlock, pressing lock/unlock a second time will activate the arm/disarm chirps respectively. The system will only sound the arm/disarm chirps upon a second press of the lock/unlock buttons.

OFF - normal arm/disarm chirps upon the first press of lock/unlock.

Feature Bank 3 - Output Control

1 - Extended Lock Pulse: Controls the timing of the BLUE and GREEN lock output wires.

1 Second - Single 1 second lock pulse, single 1 second unlock pulse.

3.5 Seconds - Single 3.5 second lock pulse, single 3.5 second unlock pulse.

1 Second Lock, Double Pulse Unlock - Single 1 second lock pulse, double 1 second unlock pulse.

30 Second Lock, Double Pulse Unlock - Single 30 second lock pulse, double 1 second unlock pulse.

Double Pulse Lock, 1 Second Unlock - Double 1 second lock pulse, single 1 second unlock pulse.

2 - Factory Disarm: Controls the timing of the LT. GREEN/BLACK factory disarm output.

Factory Disarm - Single 1 second pulse with unlock and remote start activation.

2nd Unlock - Same output as unlock with 2nd press of unlock.

Start Status - Continuous (-) output during the remote start cycle.

3 - Ignition Controlled Locks: Control of door locks when the ignition is cycled ON or OFF.

OFF - Door locks not activated by ignition.

Lock and Unlock - Doors lock when ignition is turned on and unlock when ignition is turned off.

Lock Only - Doors lock when ignition is turned on only.

Unlock Only Doors unlock when ignition is turned off only.

4 - Horn Output Timing: Control the minimum horn pulse time in milli seconds, some vehicle will require a longer pulse to activate the factory horn.

16mS 10mS 30mS 40mS 50mS

5 - Real Panic: Controls the panic out when triggered from the transmitter.

ON - Randomized horn honks when panic is triggered.

OFF - Standard pattern horn honks when panic is triggered.

Feature Bank 4 - Remote Start Control

1 - RF Start Chirp: Turns remote start activation confirmation chirps ON or OFF.

2 - Run Time: Controls the time in minutes that the vehicle will stay running under control of the remote start until the system times out. The system may also be shut down at any time by use of the transmitter or system shutdowns.

3 - Running Lights: Controls the WHITE parking light output wire during remote start.

Steady - Parking lights constant during the remote start cycle.

Flashing - Parking lights flash at a slow pace during the remote start cycle.

4 - Tach Mode: Determines how the system monitors the engine running during remote start.

Tach - Hard wired directly to the tach wire of the vehicle to monitor AC voltage.

Tachless (Crank Average/Voltage) - Determines crank time by averaging the last 8 times the vehicle was started with the key and then monitors the change in voltage after remote start.

Hybrid (Crank Average / No Voltage) - Determines crank time by averaging the last 8 times the vehicle was started with the key.

DBI Port - Monitors the vehicle's tach rate through an interface module connected to the DBI port.

5 - Voltage Level: The voltage variance for remote start when set to tachless. (see tach mode)

HIGH - The variance in battery voltage from before the remote start is activated to after the engine is running must be greater than 0.5 volts.

LOW - The variance in battery voltage from before the remote start is activated to after the engine is running may be less than 0.5 volts.

6 - Crank Time: Preset output times for the PURPLE starter wire.

1 Second 0.8 Seconds 1.5 Seconds 2 Seconds 4 Seconds

7 - Crank Average / Crank Time: The length of time in which the remote start will crank the vehicle's starter.

Crank Average - Determines crank time by averaging the last 8 times the vehicle was started with the key.

Preset Time - Preset starter output time. (see crank time)

8 - Gas / Diesel: Selects engine type and delay time for the starter output wire during remote start activation.

Gas - Gasoline engine, no delay for the starter output wire.

10 Second Delay - Diesel engine, delays the starter output wire for 10 seconds after the ignition has been powered up by the remote start.

15 Second Delay - Diesel engine, delays the starter output wire for 15 seconds after the ignition has been powered up by the remote start.

20 Second Delay - Diesel engine, delays the starter output wire for 20 seconds after the ignition has been powered up by the remote start.

45 Second Delay - Diesel engine, delays the starter output wire for 45 seconds after the ignition has been powered up by the remote start.

9 - Single / Double Pulse Start: Switches the remote start activation between a single or double press from the transmitter.

10 - IGN 2 Output: Programmable high current output.

Ignition 2 - Ignition output during remote start.

Accessory - Accessory output during remote start.

Start / Crank - Crank output during remote start.

11 - 2 or 3 Hour Start: When activated, the remote start will activate and run for the programmed time and shut down every 2 or 3 hours.

Transmitter Button Functions

1 Way Transmitter	Lock	Unlock	Car Find / Panic	Start	N/A	Operation Method
Lock	X					Press and Release
Unlock		X				Press and Release
Trunk		X				Push and Hold (3 Sec)
Car Finder			X			Press and Release
Panic			X			Push and Hold (3 Sec)
Remote Start				X		Press and Release (1 or 2 times depending on selectable option)
Remote Start Shut Down				X		Push and Hold (3 Sec)
Run Time Extention				X		Press and Release 4 times.
2 / 3 Hour Start				X		Ignition ON/OFF, Press and Hold Valet Button, Press Start 4 times
Daily Start Timer	X			X		Press Lock + Start

2 Way Transmitter	Lock	Unlock	Car Find / Panic	Start	Function	Operation Method
Lock	X					Press and Release
Unlock		X				Press and Release
Trunk		X				Push and Hold (3 Sec)
Car Finder			X			Press and Release
Panic			X			Push and Hold (3 Sec)
Remote Start				X		Press and Release (1 or 2 times depending on selectable option)
Remote Start Shutdown				X		Push and Hold (3 Sec)
Run Time Extention				X		Press and Release 4 times.
2 / 3 Hour Start				X		Ignition ON/OFF, Press and Hold Valet Button, Press Start 4 times
Daily Start Timer	X			X		Press Lock + Start
Menu					X	Press and Hold

Remote Start Shutdown Diagnostics

If the remote start shuts down or fails to start, the parking lights will flash one of the patterns below indicating the shutdown input.

To manually enter diagnostics and view the last shutdown, turn the ignition ON and press and release the  button.

LED FLASHES

3 Flashes

4 Flashes

7 Flashes

SHUTDOWN ZONE

Hood Input

Brake Input

Remote Start Valet Mode

Tach not learned / Crank Average not learned

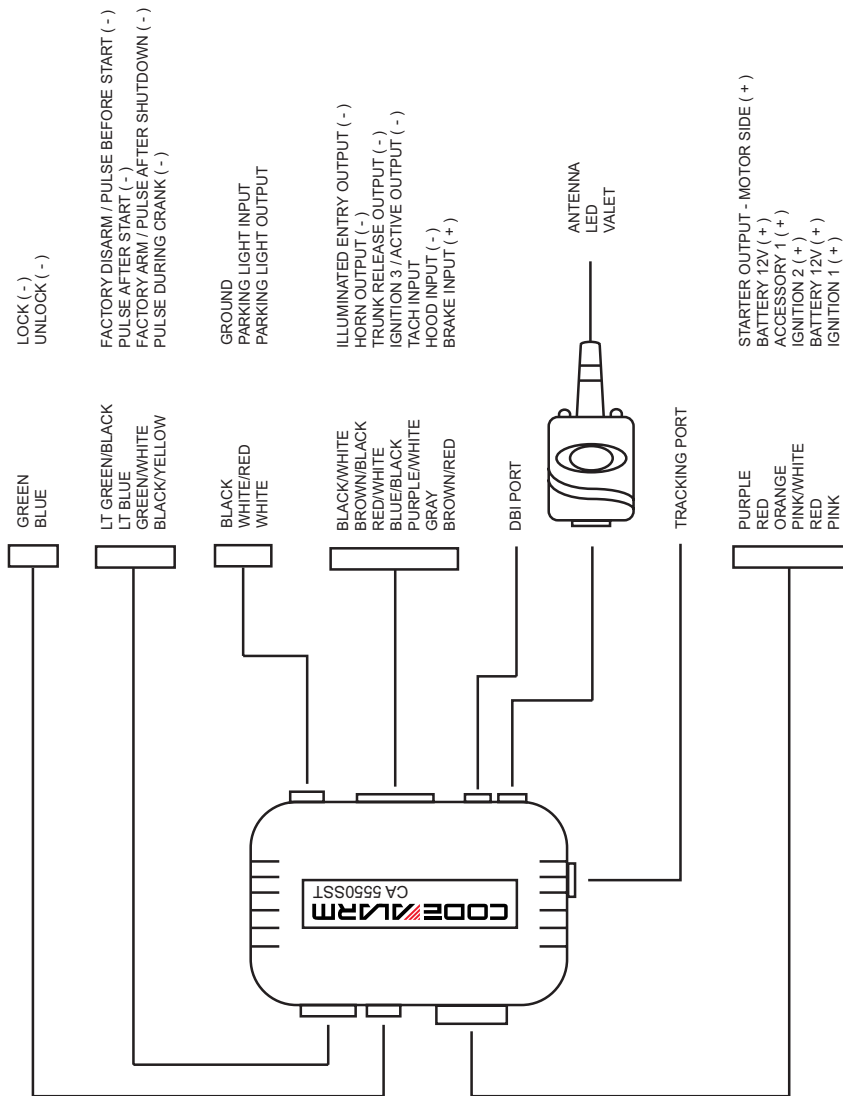

Audiovox Electronics Corporation.
Customer Service 1-800-421-3209
WWW.CODE-ALARM.COM

FCC COMPLIANCE

This device complies with Part 15 of the FCC rules and with RSS-210 of Industry Canada. Operation is subject to the following two conditions:

1. This device may not cause harmful interference, and
2. This device must accept any interference received, including any interference that may cause undesired operation.

Warning!

Changes or modifications not expressly approved by the party responsible for compliance could void the user's authority to operate the equipment.