

# **CODE ALARM**

## **PROFESSIONAL SERIES**

### **Remote Start Installation Guide**

# **ca 4552**

<b>Before You Begin .....</b>	<b>3</b>
<b>Wire Connection Guide .....</b>	<b>4</b>
4 Pin Main Harness .....	5
3 Pin Parking Light Harness .....	7
6 Pin Start Harness .....	8
4 Pin Alternate Harness .....	9
2 Pin Door Lock Output Harness .....	10
<b>Additional Ports .....</b>	<b>11</b>
Antenna / LED / Programming Port .....	11
DBI Port .....	11
Telematic Interface Port .....	11
<b>Set Up &amp; Programming .....</b>	<b>12</b>
Transmitter Programming .....	12
Manual Feature Programming .....	12
Programming Feature Banks .....	13
Tach Programming .....	14
Smart Tachless Mode .....	14
<b>Feature Descriptions .....</b>	<b>15</b>
<b>Transmitter Button Functions .....</b>	<b>18</b>
<b>2 Way Transmitter Notifications .....</b>	<b>18</b>
<b>Remote Start Shutdown Diagnostics .....</b>	<b>19</b>
<b>System Layout .....</b>	<b>20</b>

## BEFORE YOU BEGIN

### **PROFESSIONAL INSTALLATION STRONGLY RECOMMENDED**

#### ***Installation Precautions:***



Roll down window to avoid locking keys in vehicle during installation



Avoid mounting components or routing wires near hot surfaces



Avoid mounting components or routing wires near moving parts



Tape or loom wires under hood for protection and appearance



Use grommets when routing wires through metal surfaces



Use a Digital Multi Meter for testing and verifying circuits. **DO NOT USE A TEST LIGHT, OR "COMPUTER SAFE PROBE"** as these can set off air bags or damage vehicle computers.



**Technical Support (800) 421-3209**  
or go to  
<http://techservices.codesystems.com>

## 4 Pin Main Harness

4 PIN MAIN	1	BLUE/BLACK	IGNITION 3 ( - )
	2	PURPLE/WHITE	TACH INPUT
	3	GRAY	HOOD PIN INPUT ( - )
	4	BROWN/RED	BRAKE INPUT ( + )

## 3 Pin Parking Light Harness

3 PIN LIGHTS	1	BLACK	GROUND
	2	WHITE/RED	PARKING LIGHT INPUT
	3	WHITE	PARKING LIGHT OUTPUT

## 6 Pin Start Harness

6 PIN START	1	PURPLE	STARTER OUTPUT - MOTOR SIDE
	2	RED	BATTERY 12V ( + )
	3	ORANGE	ACCESSORY 1 ( + )
	4	PINK/WHITE	IGNITION 2 ( + )
	5	RED/WHITE	BATTERY 12V ( + )
	6	PINK	IGNITION 1 ( + )

## 4 Pin Alternate Output Harness

4 PIN ALTERNATE OUTPUT	1	LT GREEN/BLACK	FACTORY DISARM / PULSE BEFORE START ( - )
	2	LT BLUE	FACTORY ARM / PULSE AFTER START ( - )
	3	GREEN/WHITE	PULSE AFTER SHUTDOWN ( - )
	4	BLACK/YELLOW	PULSE DURING CRANK ( - )

## 2 Pin Lock Output Harness

2 PIN LOCK	1	BLUE	UNLOCK ( - )
	2	OPEN	

## 4 Pin Main Harness

1 BLUE/BLACK

IGNITION 3 / ACTIVE OUTPUT ( - )

The Active Output/Ignition 3 output wire provides a ground output when the remote start function is activated and remains until 4 seconds after the remote start is shutdown. The Ignition 3 output wire can be used for several functions listed below. If this wire will be used for multiple application's a 1 amp diode is required in-line with the stripe facing the control module.

Factory transponder (coded key) bypass.

General Motors VATS bypass, see the following diagram. Use an SPDT relay (not supplied).

Ignition 3 output, see the following diagram. Use an SPDT relay (not supplied).

Accessory 2/3 output, see the following diagram. Use an SPDT relay (not supplied).

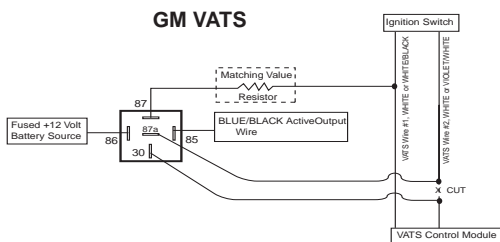

### Ignition 3

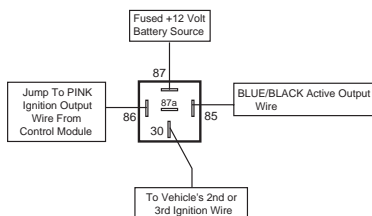

### Accessory 2/3

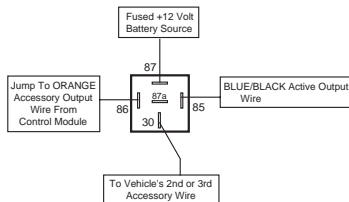

**2 PURPLE/WHITE****TACH INPUT**

Locate the vehicle's ignition coil or fuel injector in the engine compartment.

*Verification:* Test using the following procedure:

1. Set voltmeter to AC VOLTS.
2. Attach positive lead of a volt meter to a constant 12-volt source.
3. Attach negative lead of a volt meter to the wire to be tested.
4. Start the engine.
5. Have someone press on the gas pedal slightly as you monitor the meter. If connected to the correct wire, the voltage reading will increase as the engine's RPM increases.

Connect the PURPLE/WHITE wire to the negative side of the vehicle ignition coil or fuel injector.

**3 GRAY****HOOD PIN INPUT ( - )**

Install a Hood Pin Switch and connect to the GRAY wire. This connection is required for Remote Start.

*Verification:* This wire when connected will register ground when the vehicle's hood is opened.

Connect the GRAY wire to the hood pin.

**NOTE:** Be sure to loom the wire, and seal the grommet.

**4 BROWN/RED****BRAKE INPUT ( + )**

Locate the vehicle's brake light wire at the brake pedal mounted switch. This connection is required for Remote Start.

*Verification:* This wire registers positive voltage when the brake pedal is pressed.

Connect the BROWN/RED wire to the vehicle's brake light wire.

## 3 Pin Parking Light Harness

1	BLACK	GROUND
---	-------	--------

Connect the BLACK wire to a solid chassis ground point using a ring terminal and self tapping screw (not supplied). Scrape away paint from the grounding point to ensure a good connection. The recommended grounding point is a metal surface in the driver's side kick panel area.

**NOTE:** Do not ground the BLACK wire with any other vehicle components.

2	WHITE/RED	PARKING LIGHT INPUT
---	-----------	---------------------

3	WHITE	PARKING LIGHT OUTPUT
---	-------	----------------------

Locate the parking light output wire at the vehicle's light switch.

*Verification:* This wire registers positive voltage when the parking lights are turned on.

Positive switching Parking Lights:

Connect the WHITE/RED wire to a 15 Amp max fused battery source.

Connect the WHITE wire to the parking light output wire.

Negative switching Parking Lights:

Connect the WHITE/RED wire to a good chassis ground.

Connect the WHITE wire to the parking light output wire.

## 6 Pin Start Harness

1	PURPLE	STARTER OUTPUT ( + )
---	--------	----------------------

Locate the vehicle starter wire.

*Verification:* This wire registers voltage *only* when the key is turned to the START position.

*Verification:*

The starter wire registers voltage when the key is turned to the START position.

Connect the PURPLE wire to the MOTOR SIDE of the vehicle starter wire.

2	RED	BATTERY 12V ( + )
---	-----	-------------------

Locate 1 of the vehicle's constant 12 Volt battery wires at the ignition switch.

*Verification:* This wire will register ( + ) voltage in all positions of the ignition switch.

Connect the RED wire to the constant 12 Volt battery wire.

**NOTE:** Remove all fuses until all connections are made.

3	ORANGE	ACCESSORY 1 ( + )
---	--------	-------------------

Locate the vehicle's accessory wire at the ignition switch.

*Verification:* This wire registers voltage when the key is turned to ACC (Accessory) and the ON (or RUN) position. The voltage drops out when the key is turned to the START (or CRANK) position.

Connect the ORANGE wire to the vehicle's accessory wire.

4	PINK/WHITE	IGNITION 2 ( + )
---	------------	------------------

Locate the vehicle's 2nd ignition wire at the ignition switch (if equipped).

*Verification:* This wire registers voltage when the key is turned to the ON (or RUN) position, but not the ACC (Accessory) position. The voltage does not drop out when the key is turned to the START (or CRANK) position.

Connect the PINK/WHITE wire to the vehicle's ignition 2 wire.

**Programmable output:** IGN, ACC, Start.



5 RED/WHITE

BATTERY 12V ( + )

Locate 1 of the vehicle's constant 12 Volt battery wires at the ignition switch.

*Verification:* This wire will register ( + ) voltage in all positions of the ignition switch.

Connect the RED/WHITE wire to the constant 12 Volt battery wire.

**NOTE:** Remove all fuses until all connections are made.

6 PINK

IGNITION 1 ( + )

Locate the vehicle's ignition wire at the ignition switch.

*Verification:* This wire registers voltage when the key is turned to the ON (or RUN) position. The voltage does not drop out when the key is turned to the START (or CRANK) position.

Connect the PINK wire to the vehicle's Ignition wire.

This wire is also used for Ignition 1 Output.

## 4 Pin Alternate Output Harness

1 LT GREEN/BLACK

FACTORY DISARM /  
PULSE BEFORE START ( - )

This wire will supply a ( - ) 500mA pulse both upon disarming the system and when the remote start feature is activated. Locate the factory perimeter alarm disarm wire from the key cylinder inside the drivers door.

*Verification:* This wire registers ground if the key is turned to the unlock position in the driver's door cylinder.

This output is configurable in option programming.

2 LT BLUE

FACTORY ARM /  
PULSE AFTER START ( - )

This wire will supply a ( - ) 500mA pulse upon successful completion of the remote start activation sequence and is typically used to re-lock the vehicle's doors upon remote start if necessary.

This output is configurable in option programming.

3	GREEN/WHITE	PULSE AFTER SHUTDOWN ( - )
---	-------------	----------------------------

This wire will supply a ( - ) 500mA pulse after the remote start shuts down. This is typically used to re-lock the vehicle's doors if they unlock upon remote start shutdown. It can also be used to pulse a door pin-switch wire to prevent the vehicle's accessories from remaining on after remote start shutdown.

This output is configurable in option programming.

4	BLACK/YELLOW	PULSE DURING CRANK ( - )
---	--------------	--------------------------

Locate the vehicle's second starter (crank) wire at the ignition switch. (if equipped)

*Verification:* This wire registers voltage only in the start (crank) position of the ignition switch.

Connect the BLACK/YELLOW wire as shown in the diagram below. Use an SPDT relay (not supplied).

This output is configurable in option programming.

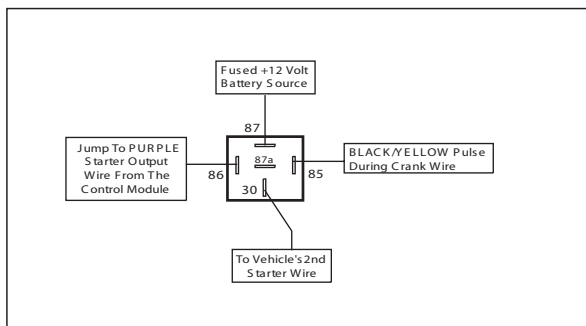

## 2 Pin Lock Output Harness

1	BLUE	UNLOCK ( - )
---	------	--------------

The door unlock output wire provides an output only while the remote start feature is active.

## Additional Ports

### Antenna Port

Mount the supplied antenna/receiver to a clear spot on the vehicle's windshield that will not block the driver's vision. A good location is usually high on the windshield near the rear view mirror. Be careful not to mount the antenna/receiver on any metallic window film, as this will effect system range. Route the antenna/receiver cable to the control module and plug into the antenna port.

### Data Bus Interface Port

This 4 pin port is used for Flashlogic Door Lock and Transponder Databus Interfaces to communicate with the vehicle's Databus. When using the DBI port to control the Flashlogic Door Lock and Transponder Interface modules the following options may be available. Please refer to the D2D (Data to Data) function list available per vehicle on the tech service web site.

Tach Input	Brake Safety Shut Down
Trunk/Hatch Open	Diesel Glow Plug Input
Door Lock Control	Passlock / Passkey Interface (GM Only)
Dome Light Supervision	Transponder Interface Activation
Factory Alarm Arm / Disarm	Manual Arm / Disarm Inputs (factory keyless controls system)

### Telematic Interface Port

This 4 pin port is used for Telematic Interface accessories, such as the CarLink ASCL1, which can control some of the following features.

Door Unlock Control	Trunk Release
Sliding Doors	AUX Output
Car Find	Remote Start

## Set Up & Programming

### Transmitter Programming - Feature Bank 1

1. Turn the ignition ON.
2. Press and hold the valet/override button.
3. Within 10 seconds the parking lights will flash (3) three times.
4. Press 1 button of each transmitter you wish to program.
5. The system will respond with 1 light flash for each accepted transmitter.
6. Pressing the override button at anytime during programming will advance to the next bank.

**NOTE:** The system will exit transmitter programming after 15 seconds of inactivity.

**NOTE:** This system has 1 button programming which programs all channels of the system.

**NOTE:** The system will hold up to 4 transmitters in memory, programming a 5th transmitter will erase the oldest transmitter in memory.

**NOTE:** This system has PTN - Programmed Transmitter Notification. Each time the ignition is turned ON, the LED will flash the number of transmitters programmed to the system.

### Manual Feature Programming - Feature Bank 2 - 5

1. Turn the ignition ON.
2. Press and hold the valet/override button.
3. Within 10 seconds the parking lights will flash (3) three times.
4. Use the valet/override button to advance through each option bank. For feature programming advance to Feature Bank 2, 3, 4 or 5, which is (4) four, (5) five, (6) six and (7) seven parking light flashes.
5. Use the transmitter  button to scroll through the selections in each feature bank, the parking lights will flash to match the feature number.
6. Press the BRAKE to change the desired feature. The LED will flash indicating the changed feature.

**NOTE:** The system will remain in feature programming mode as long as the ignition is on, there is no time limit. To exit programming turn the IGNITION OFF.

**Feature Bank 1 - 3 Flashes  
Transmitter Programming**

Refer to transmitter programming.

	<b>Feature Bank 2 - 4 Flashes Security Control</b>	<b>1 LED Flash</b>	<b>2 LED flash</b>	<b>3 LED Flash</b>	<b>4 LED Flash</b>	<b>5 LED Flash</b>	<b>6 LED Flash</b>

Feature set not available on this model.

	<b>Feature Bank 3 - 5 Flashes Output Control</b>	<b>1 LED Flash</b>	<b>2 LED flash</b>	<b>3 LED Flash</b>	<b>4 LED Flash</b>	<b>5 LED Flash</b>	<b>6 LED Flash</b>
1	Extended Lock Pulse	<b>1 Second</b>	3.5 Seconds	Double Pulse Unlock			

	<b>Feature Bank 4 - 6 Flashes Remote Start Control</b>	<b>1 LED Flash</b>	<b>2 LED flash</b>	<b>3 LED Flash</b>	<b>4 LED Flash</b>	<b>5 LED Flash</b>	<b>6 LED Flash</b>
1	RF Start Chirp	NA					
2	Run Time	<b>15 Minutes</b>	5 Minutes	10 Minutes	20 Minutes	45 Minutes	60 Minutes
3	Running Lights	<b>Steady</b>	Flashing				
4	Tach Mode	<b>Tach</b>	Tachless (Crank Average / Voltage)	Hybrid (Crank Average / NO Voltage)	DBI Port		
5	Voltage Level	<b>High</b>	Low				
6	Crank Time	<b>1.0 Seconds</b>	0,8 Seconds	1,5 Seconds	2,0 Seconds	4,0 Seconds	
7	Crank Averaging / Crank Time	<b>Averaging</b>	Preset Time				
8	Gas / Diesel	<b>Gas</b>	10 Second Delay	15 Second Delay	20 Second Delay	45 Second Delay	
9	Single / Double Pulse Start	<b>Double Press</b>	Single Press				
10	IGN 2 Output	<b>Ignition 2</b>	Accessory	Start / Crank			
11	2 or 3 Hour Start	<b>3 Hour</b>	2 Hour				

	<b>Feature Bank 5 - 7 Chirps 4 Pin Alternate Output Control</b>	<b>1 LED Flash</b>	<b>2 LED flash</b>	<b>3 LED Flash</b>	<b>4 LED Flash</b>	<b>5 LED Flash</b>	<b>6 LED Flash</b>
1	Lt Green / Black Output	<b>Pulse Before Start / During Unlock</b>	Ground While Running	Ignition	Accessory	Pulse During Crank	
2	Lt Blue Output	<b>Pulse After Start / During Lock</b>	Ground While Running	Ignition	Accessory	Pulse During Crank	
3	Green / White Output	<b>Pulse After Shutdown</b>	Ground While Running	Ignition	Accessory	Pulse During Crank	
4	Black / Yellow Output	<b>Pulse During Crank</b>	Ground While Running	Ignition	Accessory		

## Tach Programming

**The unit will not operate unless tach is programmed or tachless option is turned ON.** If an attempt is made to start the vehicle via the remote start without first programming tach, the unit will flash the parking lights 7 times indicating tach has not been learned and stored. If the tach rate is not properly programmed to the specific vehicle, the unit may not realize that the vehicle is running in certain instances and reengage the starter motor.

The Remote Start unit will learn the tach rate of most vehicle's single coil, multiple coil packs, or single injector. To learn tach:

1. Turn the ignition key to the ON position.
2. Press and release the valet/override button 3 times.
3. Immediately turn the ignition key OFF.
4. Press and hold the valet/override button, then start the vehicle using the key.
5. When the unit senses the tach signal, the parking lights will begin to flash.
6. Allow the vehicle to settle to a normal idle speed.
7. Release the valet/program push-button switch. The parking lights will stay on solid indicating that the learned tach signal is stored and the unit has exited tach learn mode.

**NOTE:** If the unit fails to learn tach rate due to an improper tach connection or a poor tach source, the parking lights will not flash. To correct this situation, locate and connect the PURPLE/WHITE wire to the proper tach signal, and then repeat the tach learn routine.

## Smart Tachless Mode

Smart Tachless Mode is available only if a tach signal has never been learned to the system and when activated will automatically change the Tach Mode feature in option programming to Tachless without the need to enter the feature programming mode.

1. Activate the remote start. The parking lights should begin flashing 7 times indicating no tach signal has been learned.
2. Within the 7 flash time period, press and hold the  button.
3. One extended parking light flash (1.5 seconds) will indicate the system is now in tachless mode.

## Feature Descriptions

### Feature Bank 2 - Security

Feature set not available on this model.

### Feature Bank 3 - Output Control

**1 - Extended Lock Pulse:** Controls the timing of the BLUE and GREEN lock output wires.

1 Second - Single 1 second unlock pulse.

3.5 Seconds - Single 3.5 second unlock pulse.

Double Pulse Unlock - Double 1 second unlock pulse.

### Feature Bank 4 - Remote Start Control

**2 - Run Time:** Controls the time in minutes that the vehicle will stay running under control of the remote start until the system times out. The system may also be shut down at any time by use of the transmitter or system shutdowns.

**3 - Running Lights:** Controls the WHITE parking light output wire during remote start.

Steady - Parking lights constant during the remote start cycle.

Flashing - Parking lights flash at a slow pace during the remote start cycle.

**4 - Tach Mode:** Determines how the system monitors the engine running during remote start.

Tach - Hard wired directly to the tach wire of the vehicle to monitor AC voltage.

Tachless (Crank Average/Voltage) - Determines crank time by averaging the last 8 times the vehicle was started with the key and then monitors the change in voltage after remote start.

Hybrid (Crank Average / No Voltage) - Determines crank time by averaging the last 8 times the vehicle was started with the key.

DBI Port - Monitors the vehicle's tach rate through an interface module connected to the DBI port.

**5 - Voltage Level:** The voltage variance for remote start when set to tachless. (see tach mode)

HIGH - The variance in battery voltage from before the remote start is activated to after the engine is running must be greater than 0.5 volts.

LOW - The variance in battery voltage from before the remote start is activated to after the engine is running may be less than 0.5 volts.

**6 - Crank Time:** Preset output times for the PURPLE starter wire.

1 Second      0.8 Seconds      1.5 Seconds      2 Seconds      4 Seconds

**7 - Crank Average / Crank Time:** The length of time in which the remote start will crank the vehicle's starter.

Crank Average - Determines crank time by averaging the last 8 times the vehicle was started with the key.

Preset Time - Preset starter output time. (see crank time)

**8 - Gas / Diesel:** Selects engine type and delay time for the starter output wire during remote start activation.

Gas - Gasoline engine, no delay for the starter output wire.

10 Second Delay - Diesel engine, delays the starter output wire for 10 seconds after the ignition has been powered up by the remote start.

15 Second Delay - Diesel engine, delays the starter output wire for 15 seconds after the ignition has been powered up by the remote start.

20 Second Delay - Diesel engine, delays the starter output wire for 20 seconds after the ignition has been powered up by the remote start.

45 Second Delay - Diesel engine, delays the starter output wire for 45 seconds after the ignition has been powered up by the remote start.

**9 - Single / Double Pulse Start:** Switches the remote start activation between a single or double press from the transmitter.

**10 - IGN 2 Output:** Programmable high current output.

Ignition 2 - Ignition output during remote start.

Accessory - Accessory output during remote start.

Start / Crank - Crank output during remote start.

**11 - 2 or 3 Hour Start:** When activated, the remote start will activate and run for the programmed time and shut down every 2 or 3 hours.



## Feature Bank 5 - 4 Pin Alternate Output Control

**1 - Lt Green/Black Output** : Controls the LT GREEN/BLACK output activation type and timing.

Pulse before Start / During Unlock - 1 second pulse when remote start is activated. Also a 1 second pulse when unlock is pressed.

Ground While Running - Continuous output for the entire remote start sequence until after the vehicle shuts down.

Ignition - Output becomes active with the same timing as the ignition output and does not drop out during crank.

Accessory - Output becomes active with the same timing as the accessory output, drops out during crank.

Pulse During Crank - Output becomes active with the same timing as the starter output wire, during crank only.

**2 - Lt Blue Output** : Controls the LT BLUE output activation type and timing.

Pulse After Start / During Lock - 1 second pulse after the remote start sequence and has confirmed the vehicle is running. Also a 1 second pulse when unlock is pressed.

Ground While Running - Continuous output for the entire remote start sequence until after the vehicle shuts down.

Ignition - Output becomes active with the same timing as the ignition output and does not drop out during crank.

Accessory - Output becomes active with the same timing as the accessory output, drops out during crank.

Pulse During Crank - Output becomes active with the same timing as the starter output wire, during crank only.

**3 - Green/White Output** : Controls the GREEN/WHITE output activation type and timing.

Pulse After Shutdown - 1 second pulse after the remote start has shutdown.

Ground While Running - Continuous output for the entire remote start sequence until after the vehicle shuts down.

Ignition - Output becomes active with the same timing as the ignition output and does not drop out during crank.

Accessory - Output becomes active with the same timing as the accessory output, drops out during crank.

Pulse During Crank - Output becomes active with the same timing as the starter output wire, during crank only.

**4 - Black/Yellow Output :** Controls the BLACK/YELLOW output activation type and timing.

Pulse During Crank - Output becomes active with the same timing as the starter output wire, during crank only.

Ground While Running - Continuous output for the entire remote start sequence until after the vehicle shuts down.

Ignition - Output becomes active with the same timing as the ignition output and does not drop out during crank.

Accessory - Output becomes active with the same timing as the accessory output, drops out during crank.

## Transmitter Button Functions

1 Button Transmitter	Start / Aux	Operation Method
Unlock	X	Press and Hold - During remote start only
Remote Start	X	Press and Release (1 or 2 times depending on selectable option)
Remote Start Shut Down	X	Press and Release (1 or 2 times depending on selectable option)

## 2 Way Transmitter Notifications

FUNCTION	BEEPS / LED FLASHES
Activation	1 Beep / Flash
Confirm Remote Start	4 Beeps / Flashes (repeats for 10 seconds)
Remote Start Running	1 Flash per second for duration run time
Remote Start Shutdown	1 Long Beep / Long Flash (repeats for 10 seconds)

## Remote Start Shutdown Diagnostics

If the remote start shuts down or fails to start, the parking lights will flash one of the patterns below indicating the shutdown input.

To manually enter diagnostics and view the last shutdown, turn the ignition ON and press and hold the  button for 3 seconds.

<b>LED FLASHES</b>	<b>SHUTDOWN ZONE</b>
3 Flashes	Hood Input Brake Input
4 Flashes	Remote Start Valet Mode
5 Flashes	Manual Transmission Mode not set (manual transmission models only)
7 Flashes	Tach not learned / Crank Average not learned

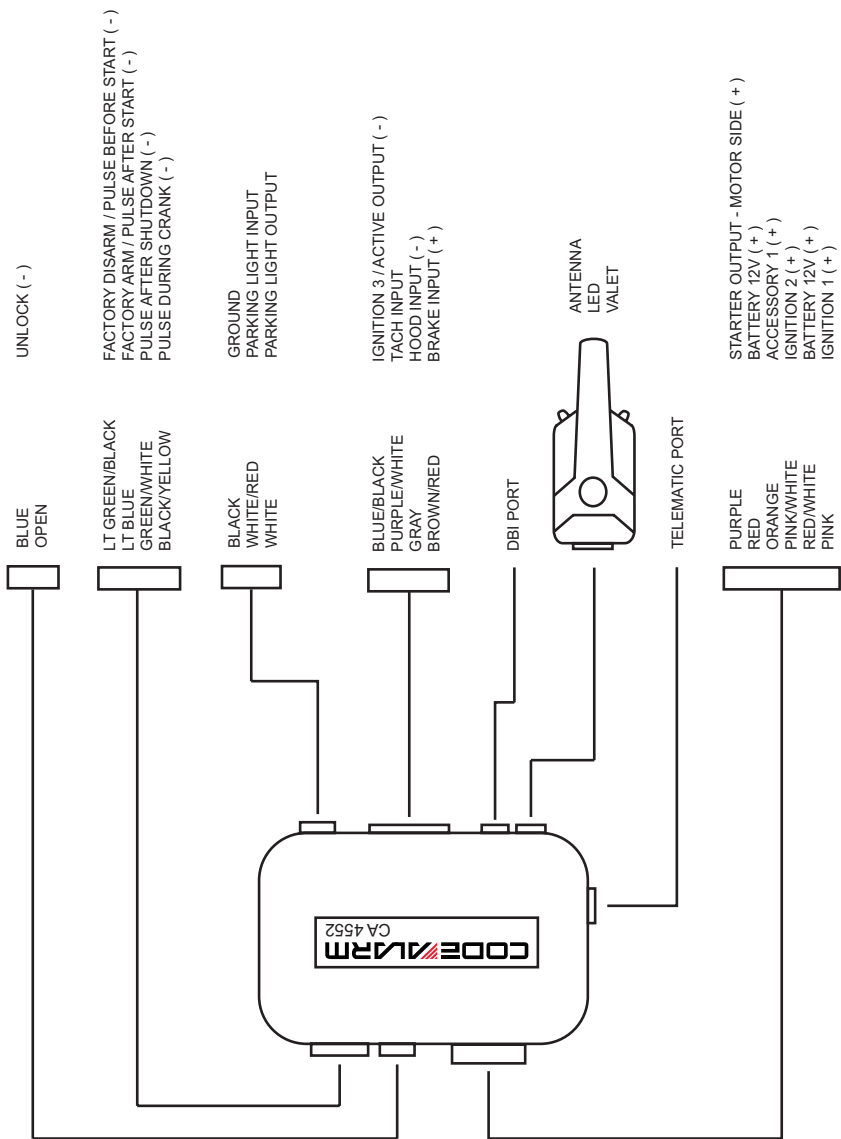



Audiovox Electronics Corporation.  
Customer Service 1-800-421-3209  
WWW.CODE-ALARM.COM

**FCC COMPLIANCE**

This device complies with Part 15 of the FCC rules and with RSS-210 of Industry Canada. Operation is subject to the following two conditions:

1. This device may not cause harmful interference, and
2. This device must accept any interference received, including any interference that may cause undesired operation.

**Warning!**

Changes or modifications not expressly approved by the party responsible for compliance could void the user's authority to operate the equipment.